



USB V.92 Dongle Modem Platform

CX-9Z-NR0226

Conexant's portfolio includes a comprehensive suite of semiconductor solutions for broadband communications and the digital home.

Controller-Based Modem with SmartDAA® 4 for PC Applications

Stylish, Turnkey Solution Surpassing PC OEM Requirements

Conexant's CX-9Z-NR0226 USB V.92 Dongle Modem design platform consists of the CX93010-11Z USB Modem with 4th Generation SmartDAA® and the CX20548-11Z SmartDAA 4 Line Side Device (LSD). The CX-9Z-NR0226 is a full turnkey USB V.92 dongle modem styled to complement today's fashionable notebooks. The attractive sleek profile with soft rounded curves is easily stored in the smallest of notebook cases. Conexant has leveraged its extensive experience in working with PC manufacturers and expertise in analog modem technology to develop a modem that will withstand the demands of the toughest PC OEMs and surpass all categories of standards testing for safety and Electromagnetic Compatibility (EMC).

Low Cost

The CX-9Z-NR0226 incorporates several cost-saving features. The CX93010-11Z is offered in a small 20-pin Quad Flat No-Lead (QFN) package allowing for the small yet cost efficient PCB. The CX20548 SmartDAA 4 LSD builds on three generations of market leading silicon DAA devices. It reduces Bill of Material (BOM) cost and necessary board space, making it the most cost efficient silicon DAA in the market. It eliminates the need for costly analog transformers, relays and opto-isolators typically used in discrete DAA implementation for country-specific modem configurations. The result is a worldwide reduced system cost solution using a single bill of materials. The SmartDAA 4 is system-powered, making it the most reliable and best performing silicon DAA in the market. The SmartDAA 4 is shipping in every top PC OEM continuing Conexant's long tradition of providing the most Internet connections via analog modems than all of its competitors combined.

Quick Time-to-Market

The CX-9Z-NR0226 is pre-tested for worldwide telecom compliance and can be transferred to any board Original Design Manufacturer (ODM) for fast time to market. The OEM can customize the design to their liking by adding their own color scheme and logo. The design is fully controlled by Conexant from the PCB to the USB cable and the ID designs to assure consistent product quality.

The CX-9Z-NR0226 is a hardware modem using the CX93010-11Z and CX20548-11Z chipset. Because it is a hardware modem, it can be easily adopted in non-x86 CPU and non-Windows OS based systems. The modem will operate with any system that has a USB CDC (Communication Device Class) driver.

Applications

- Notebook computers
- Desktop computers
- Workstations



Distinguishing Features

- Full turnkey design
- Elegant and stylish ID design
- Slim and compact
- Passes strict EMC and safety standards of the top PC OEMs
- Pre-certified for worldwide Telecom

Part Number CX-9Z-NR0226

Description USB V.92 Dongle Modem Platform

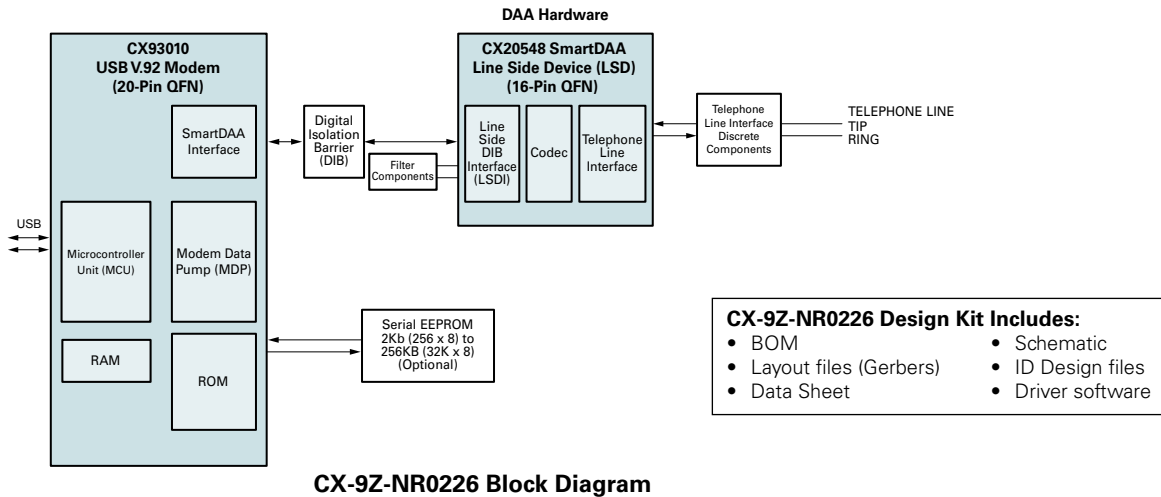

CX-9Z-NR0226 Block Diagram

Features

- Full speed (12 MHz) USB interface device implementation
 - Suspend/Resume
 - Vendor specific descriptions
 - Bus powered USB device
 - Compatible with USB 2.0
- Data modem
 - ITU-T V.92 (V.92 model)
- Modem-on-Hold (MOH)
- Quick connect (QC)
- PCM upstream
 - V.90 (V.92 model)
 - V.34 (V.92 model)
 - V.32bis, V.32, V.22bis, V.22, V.23, and V.21, Bell 212A and Bell 103
 - V.22bis fast connect
 - V.250 and V.251 commands
 - V.80 Synchronous Access Mode
- Data compression and error correction
 - V.44, V.42bis, and MNP 5 data compression
 - V.42 LAPM and MNP 2-4 error correction
- Fax modem send and receive rates up to 14.4 kbps
 - V.17, V.29, V.27 ter, and V.21 channel 2
 - EIA/TIA 578 Class 1 and T.31 Class 1.0
- Interfaces to optional serial EEPROM
- Data/Fax/Voice call discrimination
- Hardware-based modem controller
- Hardware-based digital signal processor (DSP)
- Worldwide operation
 - Complies to TBR21 and other country requirements
 - On-hook and/or off-hook Caller ID detection for selected countries
 - Call progress, blacklisting
 - Internal ROM includes default values for 63 countries
 - Additional modified country profiles can be stored in internal SRAM or optional serial EEPROM
- In-band digital call progress
- Caller waiting detection

- Caller ID detect
 - On-hook Caller ID detection
 - Off-hook Call Waiting Caller ID detection during data mode when connected to V.92 server
- Modem customization available through patch code that can be stored in optional serial EEPROM or internal SRAM
- Telephony/TAM
 - V.253 commands
 - 2-bit and 4-bit ADPCM, 4-bit IMA ADPCM, 8-bit and 16-bit linear PCM, and 8-bit μ -law and A-law PCM coding
 - 8 kHz sample rate
 - Concurrent DTMF, ring, and Caller ID detection
- Flow control and speed buffering
- Automatic format/speed sensing
- Asynchronous data
- LED driver outputs
- +5V to +3.3V voltage regulators on-chip
- +3.3V to +1.2V voltage regulators on-chip
- System compatibility – CDC-compliant systems
 - Microsoft Windows 98SE, Windows ME, Windows 2000 and Windows XP operating systems; Linux operating systems
 - Macintosh computers and Sun workstations

SmartDAA Features

- System side powered DAA operates under poor line current supply conditions
- Ring detection
- Line polarity reversal detection
- Line current loss detection
- Pulse dialing
- Line-in-use detection during on-hook operation
- Remote hang-up detection for efficient call termination
- Extension pickup detection
- Call waiting detection
- Digital PBX line protection
- Meets worldwide DC VI masks requirements

Conexant Product Portfolio

The company's broad portfolio of semiconductor products also includes client-side DSL, cable, and dial-up modem solutions; fiber optic system-on-chips; broadcast video encoders and decoders; and digital set-top box components and systems solutions. Additional products include a complete line of asymmetric and symmetric DSL central office solutions, which are used by service providers worldwide to deliver broadband data, voice, and video over copper telephone lines.

© 2008 Conexant Systems, Inc. All Rights Reserved. Conexant and the Conexant logo are registered trademarks of Conexant Systems, Inc. All other trademarks are owned by their respective owners. Although Conexant strives for accuracy in all its publications, this material may contain errors or omissions and is subject to change without notice. **THIS MATERIAL IS PROVIDED AS IS AND WITHOUT ANY EXPRESS OR IMPLIED WARRANTIES, INCLUDING MERCHANTABILITY, FITNESS FOR A PARTICULAR PURPOSE AND NON-INFRINGEMENT.** Conexant shall not be liable for any special, indirect, incidental or consequential damages as a result of its use.

www.conexant.com
General Information:
 U.S. and Canada: (888) 855-4562
 International: 1+ (949) 483-3000
Headquarters
 4000 MacArthur Blvd.
 Newport Beach, CA 92660
 Doc# PBR-

